

STUDIOTWENTYSEVEN

CAVALLETTO BOOKCASE **ANGELO MANGIAROTTI** DESIGN 1953
SIGNED, SERIAL NUMBER AND CERTIFICATE OF AUTHENTICITY

NATURAL OAK STRUCTURE WITH OPTIONAL BOTTOM STORAGE PAINTED WHITE
BROWN OR DARK OAK STRUCTURE WITH OPTIONAL BOTTOM STORAGE PAINTED GRAY
SINGLE OR DOUBLE DRAWERS WITHIN THE STORAGE UNIT
PRODUCTION TIME 14-16 WEEKS
MADE IN ITALY

COMPOSITION A - L 312

IN H 51,2 W 122,8 D 15,7
CM H 130,3 W 312 D 40

COMPOSITION B 209

IN H 51,2 W 82,2 D 16,4
CM H 130,3 W 209 D 41,8

COMPOSITION C - L 415

IN H 66,8 W 163,3 D 15,7
CM H 169,8 W 415 D 40

COMPOSITION D - L 312

IN H 66,8 W 122,8 D 16,4
CM H 169,8 W 312 D 41,8

COMPOSITION E - L 415

IN H 66,8 W 163,3 D 16,4
CM H 169,8 W 415 D 41,8

COMPOSITION F - L 209

IN H 82,4 W 82,2 D 15,7
CM H 209,3 W 209 D 40



STUDIOTWENTYSEVEN

COMPOSITION A - L 312

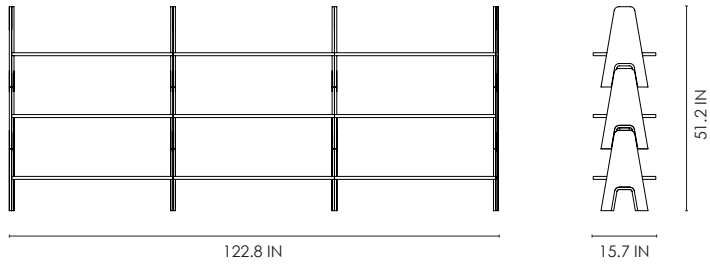

COMPOSITION B 209

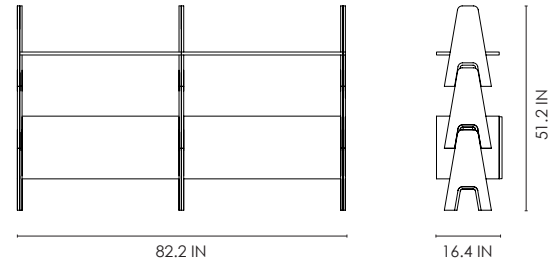

COMPOSITION C - L 415

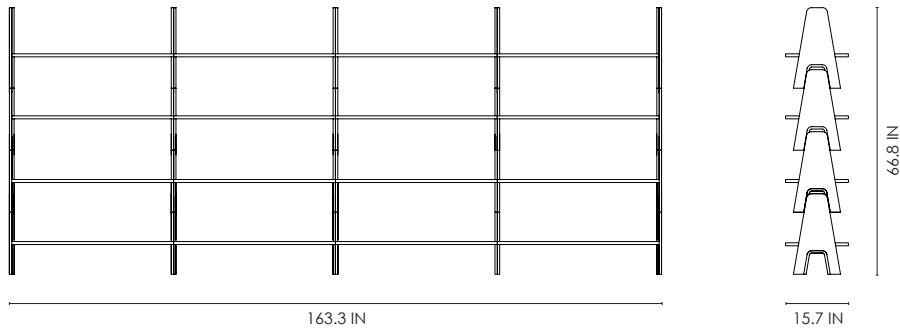

COMPOSITION D - L 312

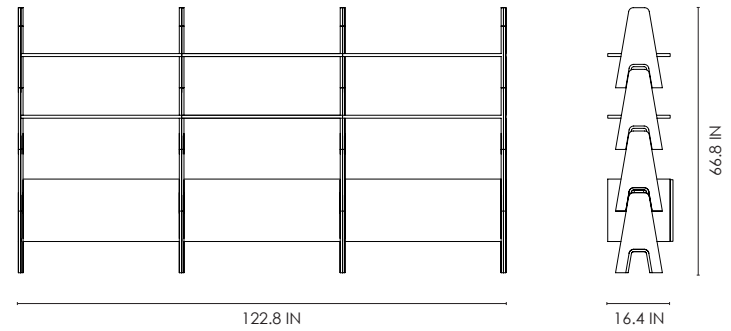

COMPOSITION E - L 415

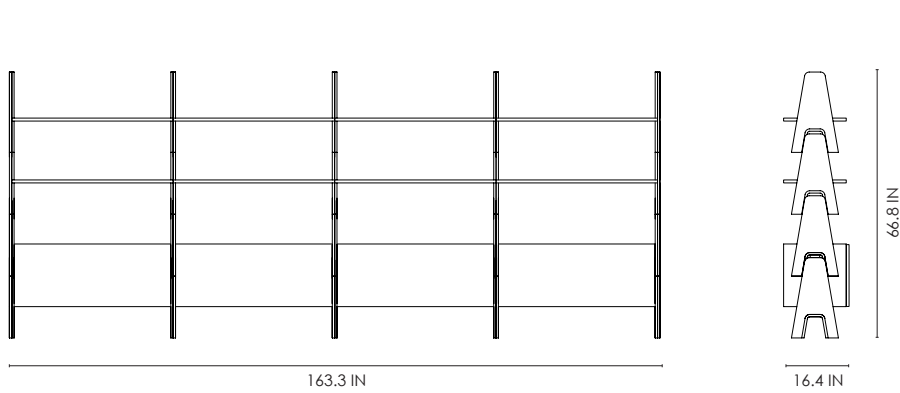

COMPOSITION F - L 209

